

RTQ2117A Charging Port Controller and Integrated 36V 3A Synchronous Buck Converter Evaluation Board

General Description

The RTQ2117A provides the electrical signatures on D+/D- to support charging schemes compatible with the USB 2.0 Battery Charging Specification BC1.2 and Chinese Telecommunication Industry Standard YD/T 1591-2009. Auto-detect mode is also integrated which supports USB 2.0 Battery Charging Specification BC1.2 Dedicated Charging Port (DCP), Divider 3 mode and 1.2V shorted mode to comply with the legacy fast charging mode of mobile devices. The high bandwidth data switch is implemented in the RTQ2117A.

The RTQ2117A integrates a high efficiency, monolithic synchronous buck converter that can deliver up to 3A output current from a 3V to 36V wide range input supply and is protected from load-dump transients up to 42V.

Table of Contents

General Description	1
Performance Sepcification Summary	2
Power-up Procedure	2
Detailed Description of Hardware	3
Bill of Materials.....	5
Typical Applications	6
Evaluation Board Layout.....	8
More Information.....	10
Important Notice for Richtek Evaluation Board.....	10

Performance Specification Summary

The Automotive HV-Buck converter has an input voltage range from 3V to 36V, and the output voltage is 5V. It can operate in forced PWM mode and PSM mode. And the current limit is implemented by RLIM for difference application. The RTQ2117A is available in a WETD-VQFN-32L 5x5 package.

Table 1. RTQ2117A Evaluation Board Performance Specification Summary

Specification	Test Conditions	Min	Typ	Max	Unit
Input Voltage Range		3	--	36	V
Output Current	RLIM = 47kΩ	3.52	4	4.48	A
Default Output Voltage	Setting by the FB pin	--	5	--	V
Operation Frequency	Setting by the RT pin	300	--	2200	kHz
Output Ripple Voltage	VIN = 12V, VOUT = 5V, IOUT = 3A	--	20	--	mVp-p
Line Regulation	CCM, VIN = 6V to 19V, VOUT = 5V, IOUT = 2.4A	--	1	--	%
Load Regulation	CCM, VIN = 12V, VOUT = 5V, IOUT < 3A	--	1	--	%
Load Transient Response	VIN = 12V, VOUT = 5V, IOUT = 1.5A to 3A	-5	--	5	%
Maximum Efficiency	VIN = 9V to 19V, VOUT = 5V, IOUT = 0A to 3A	--	91	--	%
DH+/DH- ↔ DS+/DS- Switch On-Resistance	DH+/DH- = 0V, 0.4V ION = 8mA	--	5	--	Ω
Differential -3dB Bandwidth	DH+/DH- = 400mVPP, RL = 50Ω, CL = 0pF on DS+/DS-	--	1.2	--	GHz

Power-up Procedure

1. Connect input voltage ($3V < V_{IN} < 36V$) to the VIN pin.
2. Setting MODE and RLIM for device request.
3. To enable Buck converter by the external EN pin.
4. To connect an external load to output and verify the output voltage versus applied current.

Output Voltage Setting

The output voltage set by external feedback resistors expressed in the following equation.

$$V_{OUT} = \left(1 + \frac{R1}{R2}\right) \times V_{FB}$$

where the reference voltage V_{FB} is 0.8V (typical).

The placement of the resistive divider should be as close as possible to the FB pin. For better output voltage accuracy, the divider resistors with $\pm 1\%$ tolerance or better should be used. The resistance of R2 is not larger than 170kΩ for noise immunity consideration is recommended .

Detailed Description of Hardware

Headers Description and Placement

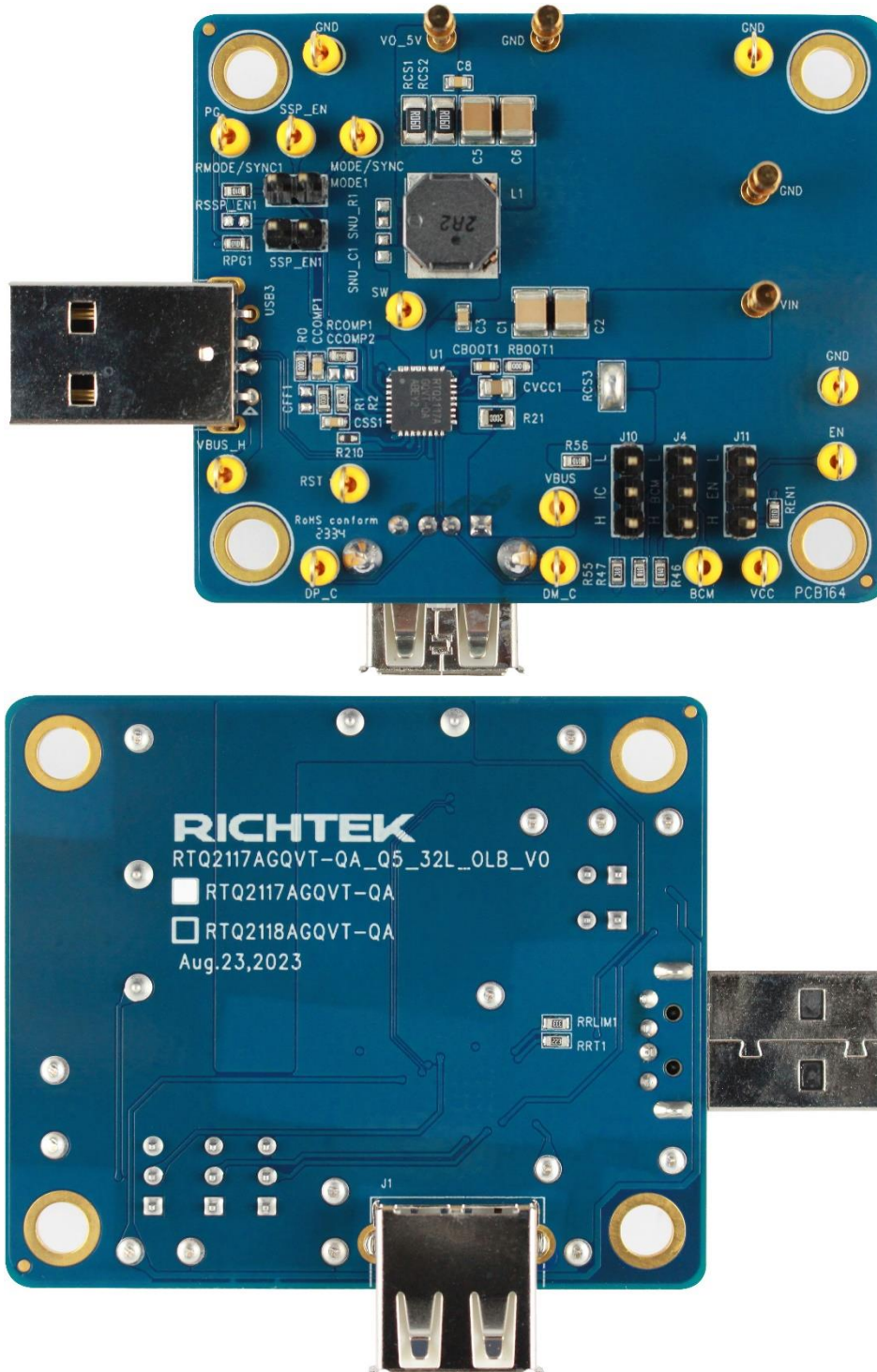

Carefully inspect all the components used in the EVB according to the following Bill of Materials table, and then make sure all the components are undamaged and correctly installed. If there is any missing or damaged component, which may occur during transportation, please contact our distributors or e-mail us at evb_service@richtek.com.

Test Points

The EVB is provided with the test points and pin names listed in the table below.

Test Point/ Pin Name	Function
VIN	Input voltage
VBUS	Output voltage
SW	Switching node
GND	GND
DS+	Data line
DS-	Data line
CC1	Type-C configuration pin
CC2	Type-C configuration pin

Bill of Materials

Reference	Count	Part Number	Description	Package	Manufacturer
U1	1	RTQ2117AGQVT-QA	USB Type-C and Power Delivery	WETD-VQFN-32L 5x5	RICHTEK
C1, C2	2	GRM31CR61H106KA12L	10µF/50V/X7R	1210	Murata
C3, C8, CBOOT	3	C1608X7R1H104K080AA	100nF/50V/X7R	0603	TDK
C5, C6	2	CL31A226KAHNNE	22µF/25V/X5R	1210	SAMSUNG
CVCC	1	C2012X7R1A106K125AC	1µF/10V/X7R	0805	TDK
CSS	1	C1608X7R1H103K080AA	10nF/50V/X7R	0603	TDK
CCOMP1	1	0603B472K500CT	4.7nF/50V/X7R	0603	WALSIN
L1	1	1217AS-H_2R2N=P3	2.2µH/9.3A (Maximum)	8.0x8.0x4.5mm	Murata
J1	1	UAF-041RGPB-CF1066	USB Type-A	USB-4P-DIP-AL	Cherng Weei
R0, RBOOT	2	WR06X000 PTL	0	0603	WALSIN
R1	1	RTT031053FTP	105k	0603	RALEC
R2	1	RTT032002FTP	20k	0603	RALEC
R21	1	WR08X2000FTL	200	0805	WALSIN
R46, R47	2	RTT031001FTP	1k	0603	RALEC
R55	1	WR06X1002FTL	10k	0603	WALSIN
R56, REN, RMODE/ SYNC, RPG	4	WR06X1003FTL	100k	0603	WALSIN
R210	1	WR04X000 PTL	0	0402	WALSIN
RCS1, RCS2	2	TGL120610FR060P05Z	0.06	1206	EVER OHMS
RCS3	1	RTT062R00FTP	short	1206	RALEC
RRLIM	1	RTT033302FTP	33k	0603	RALEC
RRT	1	WR06X2202FTL	22k	0603	WALSIN
RCOMP	1	RTT037681FTP	7.68k	0603	RALEC
USB3	1	UP2-AH-1-T	USB Type-A	12.75x18.75x5.52mm	CUI Devices

Typical Applications

EVB Schematic Diagram

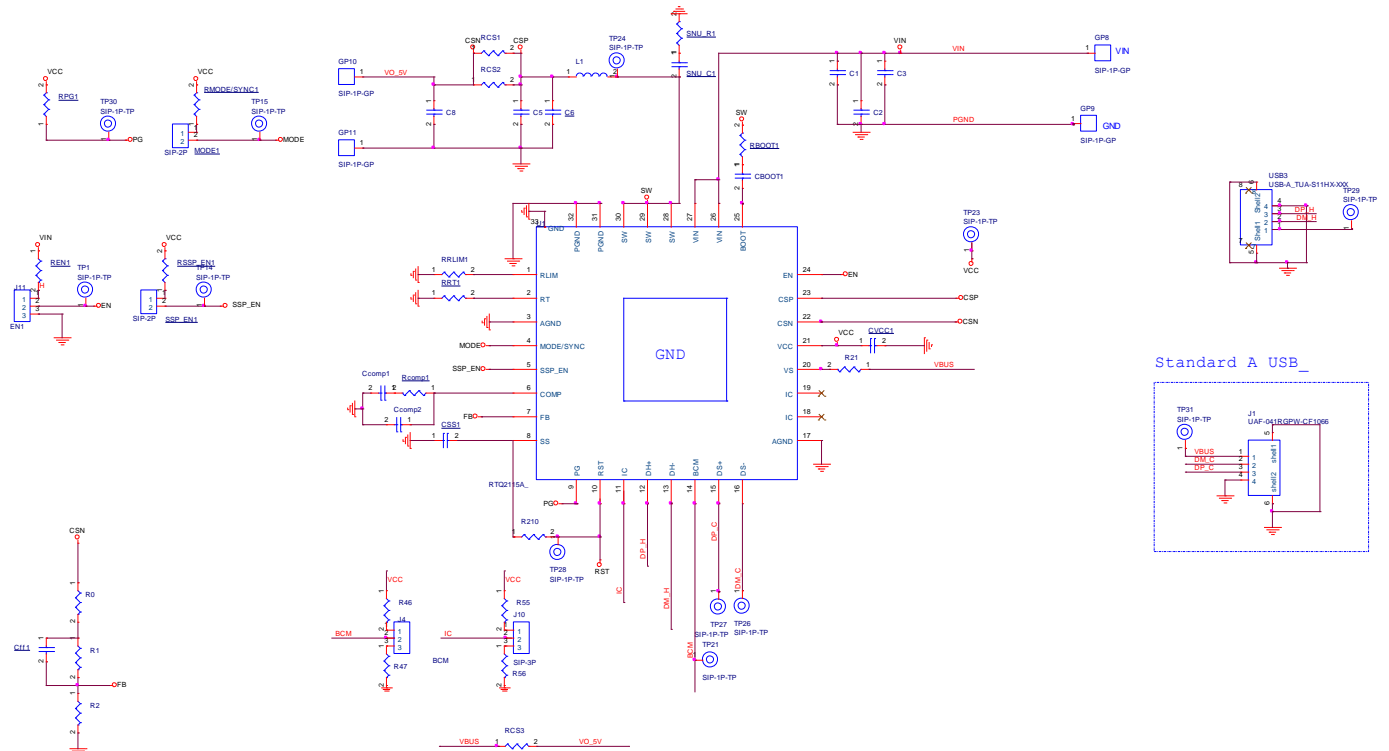

1. The capacitance values of the input and output capacitors will influence the input and output voltage ripple.
2. MLCC capacitors have degrading capacitance at DC bias voltage, and especially smaller size MLCC capacitors will have much lower capacitance.

Measure Result

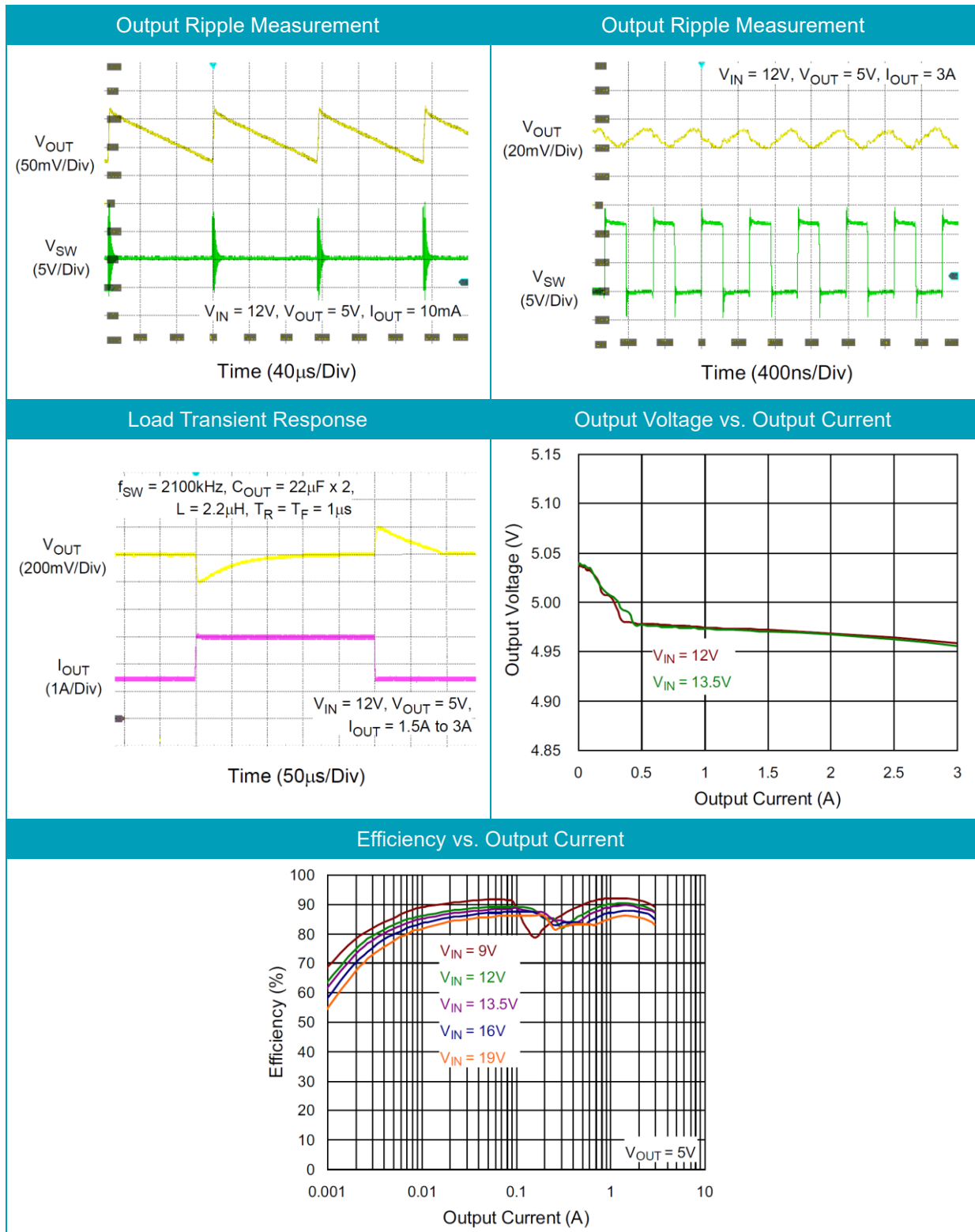

Note: When measuring the input or output voltage ripple, care must be taken to avoid a long ground lead on the oscilloscope probe. Measure the output voltage ripple by touching the probe tip directly across the output capacitor.

Evaluation Board Layout

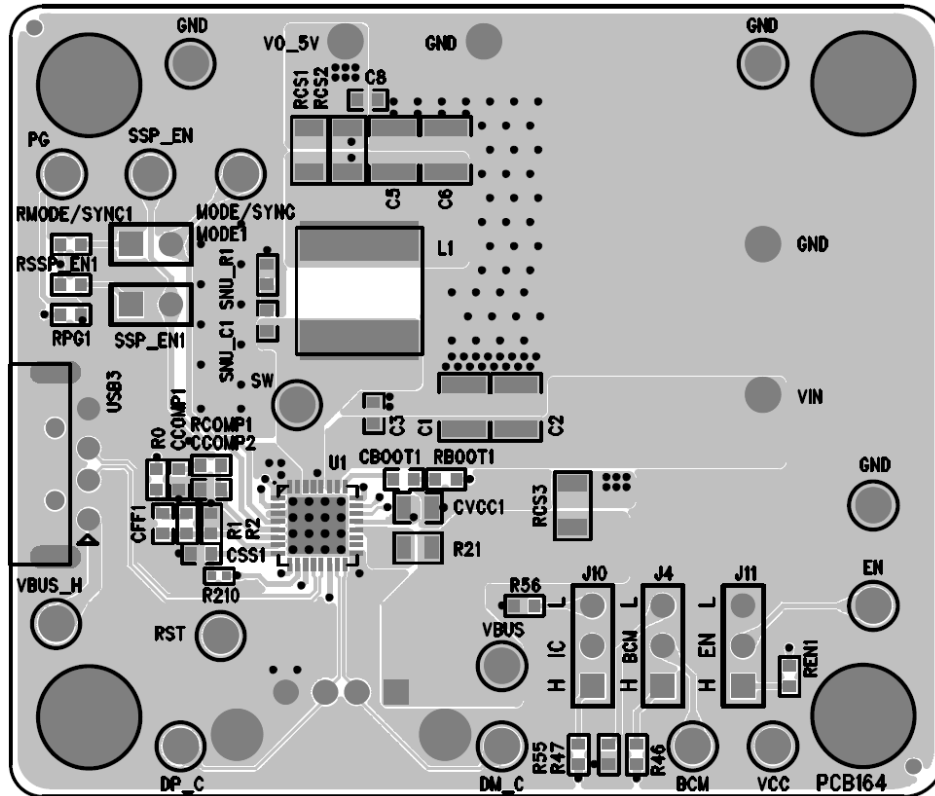

Figure 1. Top View (1st layer)

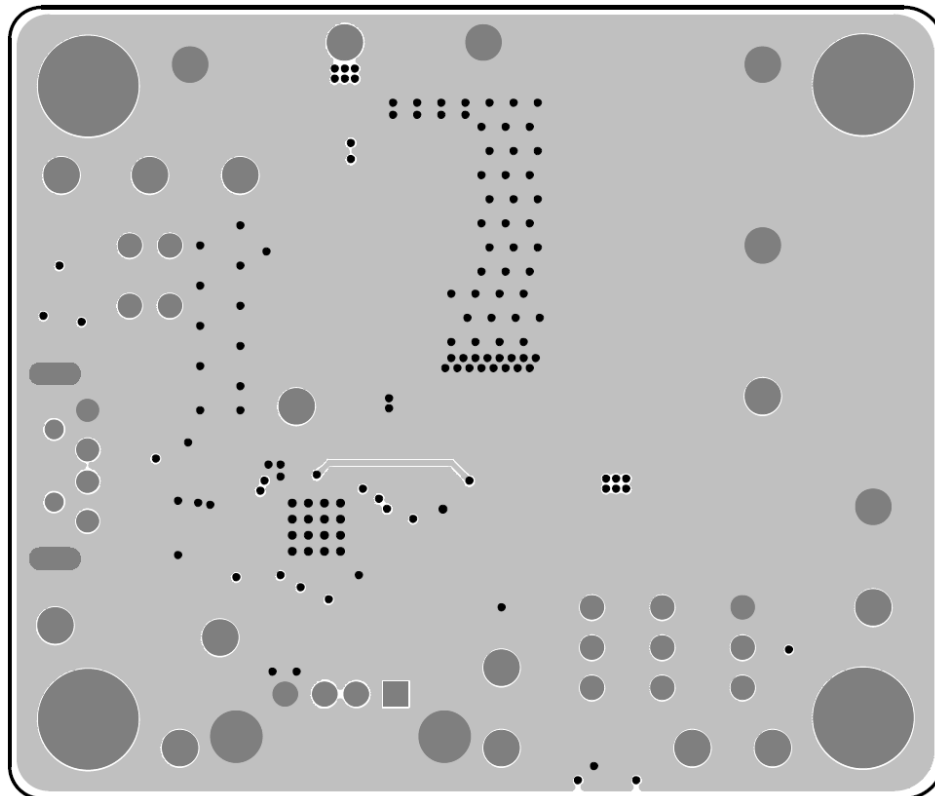

Figure 2. PCB Layout—Inner Side (2nd Layer)

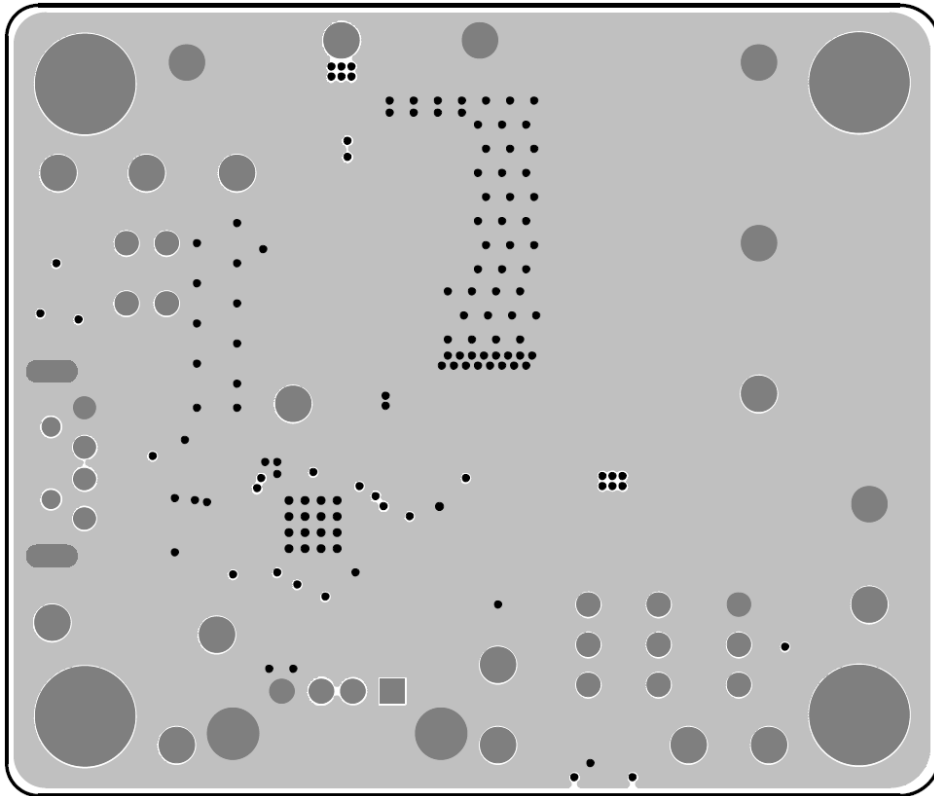

Figure 3. PCB Layout—Inner Side (3rd Layer)

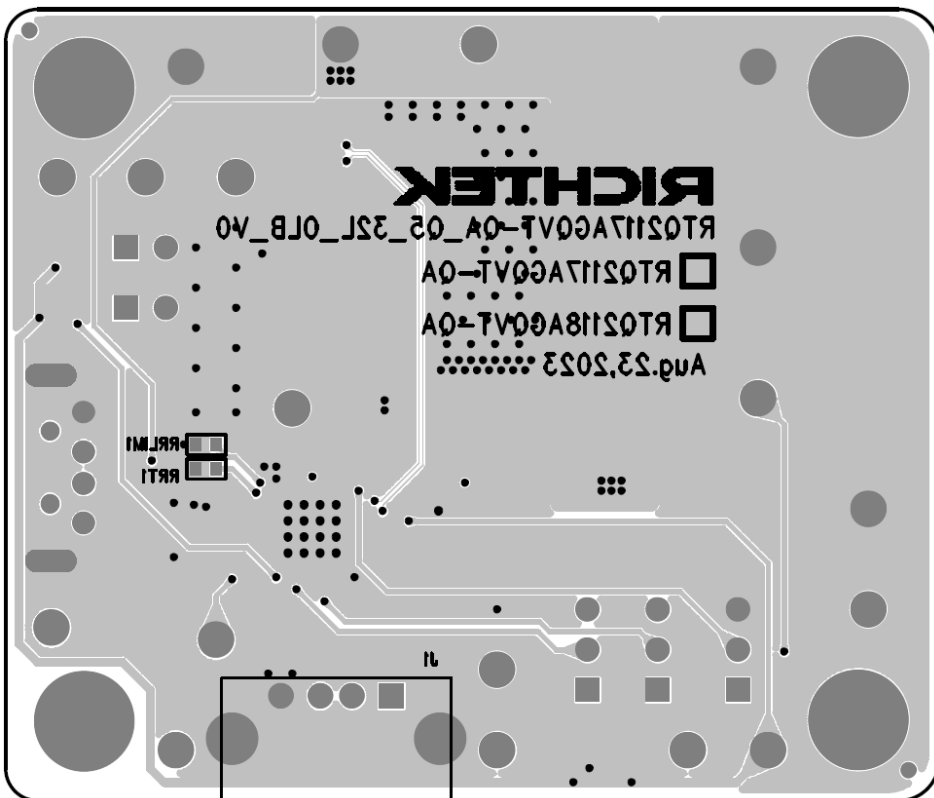

Figure 4. Bottom View (4th Layer)

More Information

For more information, please find the related datasheet or application notes from Richtek website

<http://www.richtek.com>.

Important Notice for Richtek Evaluation Board

THIS DOCUMENT IS FOR REFERENCE ONLY, NOTHING CONTAINED IN THIS DOCUMENT SHALL BE CONSTRUED AS RICHTEK'S WARRANTY, EXPRESS OR IMPLIED, UNDER CONTRACT, TORT OR STATUTORY, WITH RESPECT TO THE PRESENTATION HEREIN. IN NO EVENT SHALL RICHTEK BE LIABLE TO BUYER OR USER FOR ANY AND ALL DAMAGES INCLUDING WITHOUT LIMITATION TO DIRECT, INDIRECT, SPECIAL, PUNITIVE OR CONSEQUENTIAL DAMAGES.